

**Polycom® VVX® 500
Business Media Phone****Polycom® VVX® 600
Business Media Phone**

Need more information? Navigate to your phone's Support page from support.polycom.com/voice.

Package Contents

VVX 500 or VVX 600 Phone

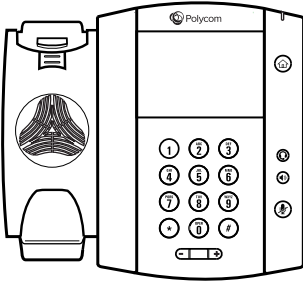
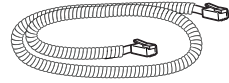

Handset and Cord

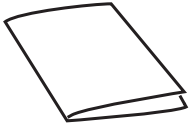

Quick Start Guide

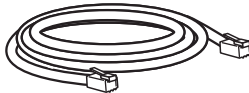

Network Cable

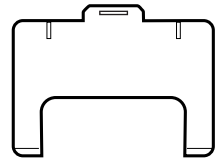

Phone Stand

Optional Accessories

For more information, contact your reseller.

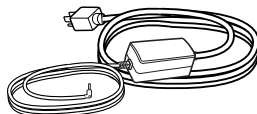

AC Power Cord and Adapter

Features

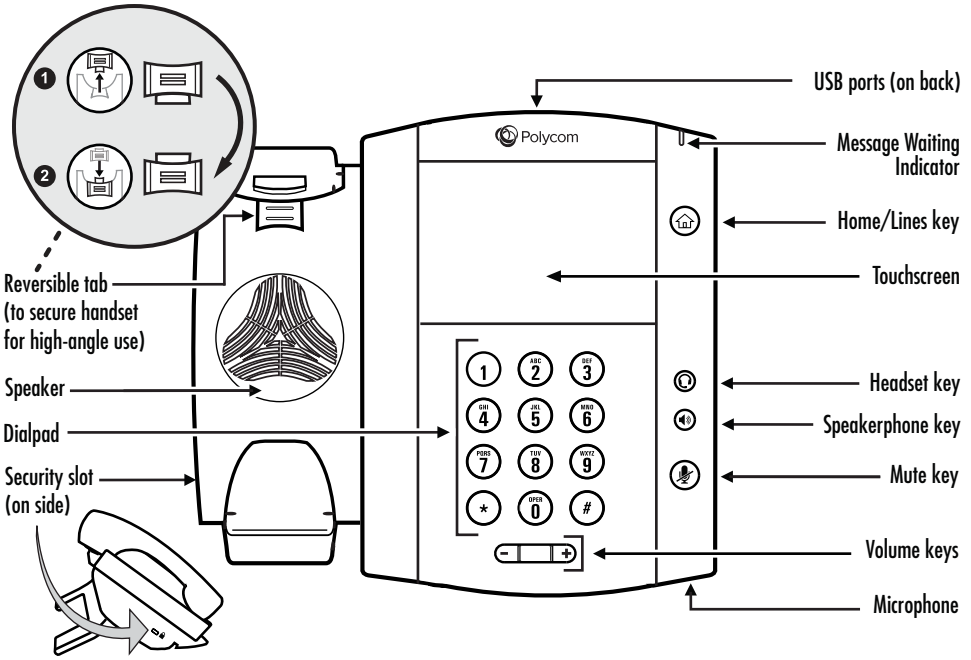

Connect Cables

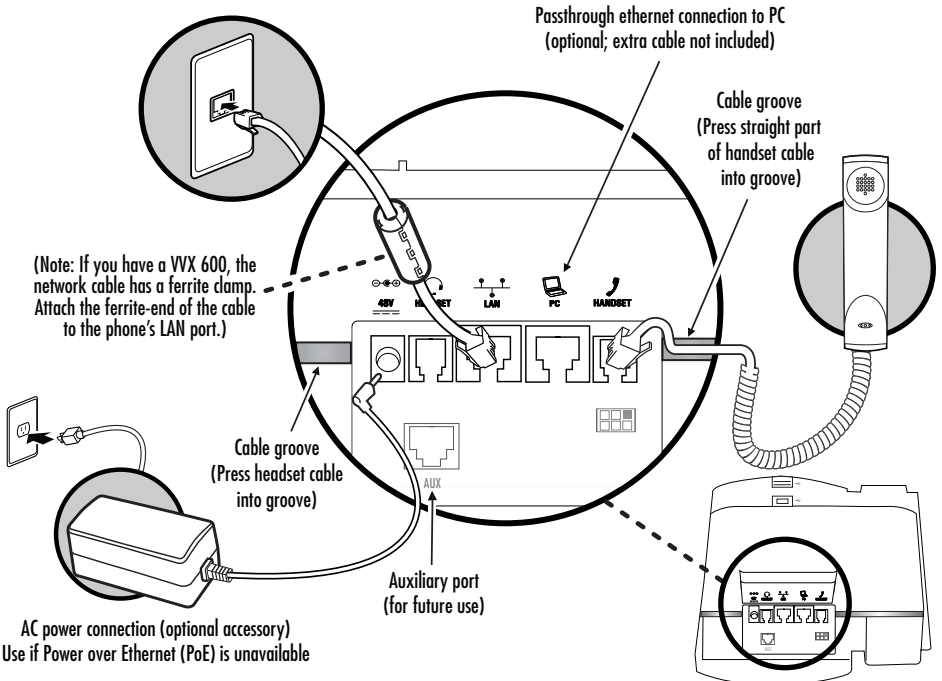

Connect Stand*

Fully insert the stand into one of the slots on the back of the phone. The slot you choose determines the angle of the phone. For high-angle use, secure the handset with the reversible tab (see **Features**).

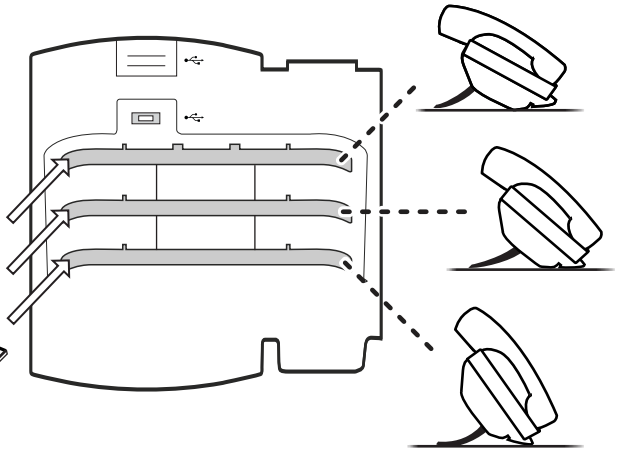
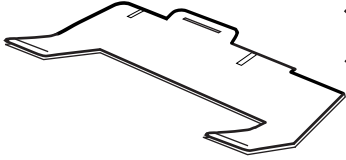

*For wallmount installation, an optional accessory is available. For more information, contact your reseller.

Connect Optional Headset

Note: Your phone supports wired and wireless headsets, including electronic hookswitch (EHS) headsets. VVX 600 phones also support Bluetooth headsets.

For connection directions, refer to your headset documentation. Standard headsets typically use the RJ-9 or USB port, while EHS headsets use the RJ-9 and serial port. The ports are on the back of your phone, as shown in the diagram.

For more information, see "Using Headsets with Polycom Phones," available from http://support.polycom.com/PolycomService/support/us/support/voice/polycom_uc/polycom_profiled_uc_software_features.html.

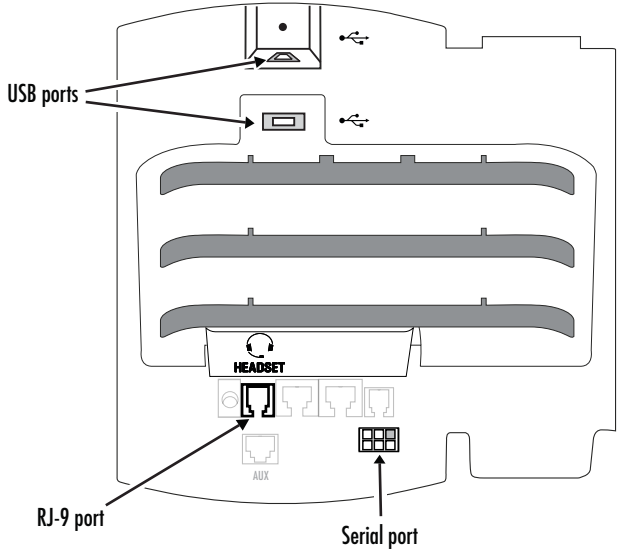

Connect Optional USB Devices

You can attach a Polycom VVX Camera, USB headset, or USB flash drive (to record calls, use the Digital Picture Frame feature, or to change the background picture on your phone). To learn more, see your phone's User Guide.

